



AC-DC POWER SUPPLIES

UNIVERSAL INPUT, UP TO 30 WATT

3.34" × 1.36" × 0.77" ENCAPSULATED PACKAGE

KUI30 SERIES

FEATURES

- 3000 Vac Reinforced Insulation
- Adjustable Output Voltage
- Internal EN55022 Class B Filter
- Low Leakage Current
- Low Standby Power
- Operating Altitude 5000 meter
- Terminal Block, Din Rail and Pin Type Options available
- Protection Class II
- Over Current Protection
- Over Voltage Protection
- Short Circuit Protection
- UL /EN /IEC60950-1
- RoHS and REACH Compliant

SELECTION GUIDE All specifications are typical at nominal input, full load and 25°C, unless otherwise noted.

Input Voltage Range Vdc	Output Voltage Vdc	Output Current Natural Convection A	Maximum Output Power W	Efficiency %	Model Number*	Input Power @ No Load mW
85 - 264	3.3	6	20	84	KUI30-33SB	40
85 - 264	5	6	30	87	KUI30-5SB	40
85 - 264	7.5	4	30	87	KUI30-7.5SB	40
85 - 264	9	3.34	30	88	KUI30-9SB	40
85 - 264	12	2.5	30	90.5	KUI30-12SB	40
85 - 264	12	2.5	30	88	KUI30-121SB	40
85 - 264	15	2	30	90.5	KUI30-15SB	40
85 - 264	15	2	30	88	KUI30-151SB	40
85 - 264	18	1.67	30	88	KUI30-18SB	40
85 - 264	24	1.25	30	89.5	KUI30-24SB	40
85 - 264	28	1.08	30	89.5	KUI30-28SB	40
85 - 264	36	0.84	30	90	KUI30-36SB	40
85 - 264	48	0.63	30	91.5	KUI30-48SB	40
85 - 264	53	0.58	30	91	KUI30-53SB	40

JST: No suffix needed

Molex: Suffix "M"

Terminal Block/Chassis Mount: Suffix "T"

Pin Type: Suffix "D"

KUI30 SERIES

Input Specifications		
Operating input voltage range	85 Min., 264 Max., Vac	AC Input
	120 Min., 370 Max., Vdc	DC Input
Input frequency, Hz	47 Min., 63 Max.	AC Input
Input current, A	0.8 Max.	100 Vac and full load
	0.4 Max.	240 Vac and full load
No load input power, mW	40 Typ.	230 Vac
Leakage current, μ A	100 Max.	264 Vac
Start up time, ms	1500 Max.	
Rise time, ms	20 Typ.	Others
	40 Typ.	24 Vout, 28 Vout, 36 Vout
	50 Typ.	48 Vout, 53 Vout
Hold up time, ms	16 Typ.	115 Vac and full load
Input inrush current, A	40 Max.	230 Vac
Input protection	T1.6A/250 Vac	Internal fuse

Output Specifications		
Output power, w	30 Max.	
Initial set voltage accuracy, %	-1.0 Min., 1.0 Max.	230 Vac and full load
Line regulation, %	-0.2 Min., 0.2 Max.	Low line to high line at full load
Load regulation, %	-0.7 Min., 0.7 Max.	No load to full load, 3.3 Vout, 5 Vout
	-0.5 Min., 0.5 Max.	Others
	-0.6 Min., 0.6 Max.	10% load to 90% load, 3.3 Vout, 5 Vout
	-0.4 Min., 0.4 Max.	Others
Voltage adjustability, %	-10 Min., 10 Max.	
Minimum load, %	0 Typ.	
Ripple and noise, mVp-p	50 Typ.	Measured by 20MHz bandwidth With a 10 μ F/25V 1206 X7R MLCC, 3.3 Vout, 5 Vout, 7.5 Vout, 9 Vout
	50 Typ.	With a 1 μ F/50V 1206 X7R MLCC, 12 Vout, 15 Vout, 18 Vout, 24 Vout, 28 Vout, 36 Vout
	50 Typ.	With a 0.1 μ F/100V 1206 X7R MLCC, 48Vout, 53Vout
Temperature coefficient, %/ $^{\circ}$ C	-0.02 Min., 0.02 Max	
Transient response	3% Vout Max.	Load step from 50-75% change at 2.5A/ μ s, peak deviation
	500 μ s Typ.	Recovery time
Over voltage protection, %	125 Min., 140 Max.	% of Vout(nom); Automatic recovery
Over load protection, %	140 Typ.	% of Iout rated; Hiccup mode
Short circuit protection	Continuous, automatics recovery	

General Specifications					
Isolation voltage, Vac	1 minute, reinforced insulation	Input to output	3000 Min.		
Isolation resistance, G Ω	500 Vdc		0.1 Min.		
Switching frequency, kHz	230 Vac	Full load	30 Min.	45 Typ.	60 Max.

Environmental Specifications					
Operating ambient temperature, $^{\circ}$ C	Natural convection	With derating	-40 Min.	+85 Max.	
Storage temperature range, $^{\circ}$ C			-40 Min.	+85 Max.	
Operating altitude, M				5000 Max.	
Shock			IEC60068-2-27		
Vibration			IEC60068-2-6		
Relative humidity	Non-condensing		5% to 95% RH		

KUI30 SERIES

Physical Specifications

Design meet safety standard	IEC/EN/UL 60950-1, 62368-1, UL:E193009, CB:UL(Demko)	
Dimensions	3.34 × 1.36 × 0.77 inches (84.83 × 34.54 × 19.56 mm)	
Weight	Connector type	119g (4.20oz)
	Pin type	106g (3.74oz)
MTBF	3.341 × 10 ⁶ hrs, MIL-HDBK-217F, Full load	

EMC Specifications

Specifications	Conditions	Level	
EMI	EN55011, EN55022 and FCC Part 15	Conducted Radiated	Class B Class B
	EN61000-3-2	Full Load	Class A
Voltage flicker	EN61000-3-3		
ESD	EN61000-4-2	Air ± 15kV and Contact ± 8kV	Perf. Criteria A
Radiated immunity	EN61000-4-3	20 V/m	Perf. Criteria A
Fast transient	EN61000-4-4	± 2kV	Perf. Criteria A
Surge	EN61000-4-5	DM ± 1kV	Perf. Criteria A
Conducted immunity	EN61000-4-6	20 Vr.m.s	Perf. Criteria A
Power frequency magnetic field	EN61000-4-8	30 A/m	Perf. Criteria A
Dip and interruptions	EN61000-4-11		Perf. Criteria A
Damped oscillatory wave	EN61000-4-18	DM ± 1kV and CM ± 2.5kV	Perf. Criteria A

Note:

- The standard modules meet either EMI Class A or Class B with external components. For further information, please contact Polytron Devices, Inc.

CAUTION: This power module is not internally fused. An input line fuse must always be used.

Characteristic Curve

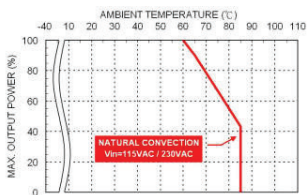

Derating Curve vs. Ambient Temperature
KUI30-xxB xx=33, 5, 7.5, 9, 121, 151, 18
Connector Option: (Blank: JST)

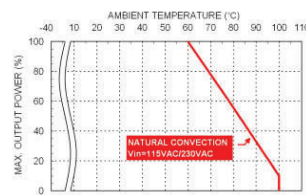

Derating Curve vs. Ambient Temperature
KUI30-xxB xx=33, 5, 7.5, 9, 121, 151, 18
Connector Option: (-M, -T, -D)

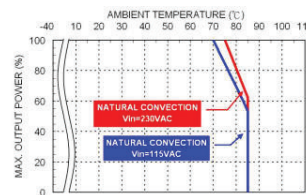

Derating Curve vs. Ambient Temperature
KUI30-xxB xx=12, 15, 24, 28, 36, 48, 53
Connector Option: (Blank: JST)

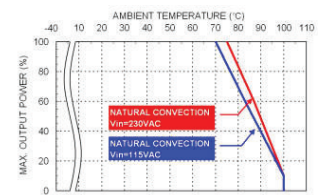

Derating Curve vs. Ambient Temperature
KUI30-xxB xx=12, 15, 24, 28, 36, 48, 53
Connector Option: (-M, -T, -D)

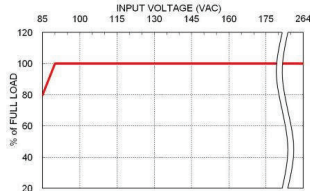

Derating Curve vs. Input Voltage

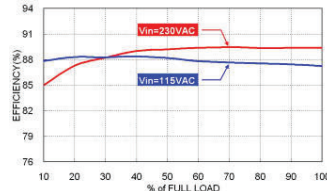

Efficiency vs. Output Load
KUI30-24SB

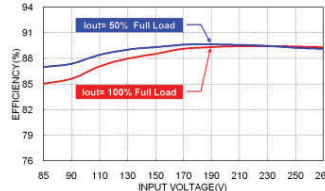

Efficiency vs. Input Voltage
KUI30-24SB

KUI30 SERIES

Mechanical Drawing

Connector Type*

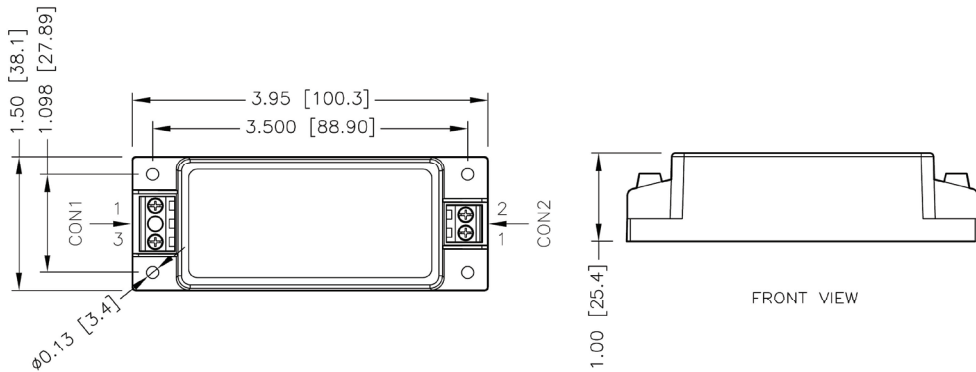

CONNECTORS

PIN	Input
1	Line
3	Neutral

	Output
1	+Vout
2	-Vout

1. All dimensions in inches (mm)
2. Tolerance :x.xx±0.02 (x.x±0.5)
x.xxx±0.01 (x.xx±0.25)
3. The screw locked torque
MAX 5Kgf.cm/0.49N.m

Din Rail Type, Suffix "T"

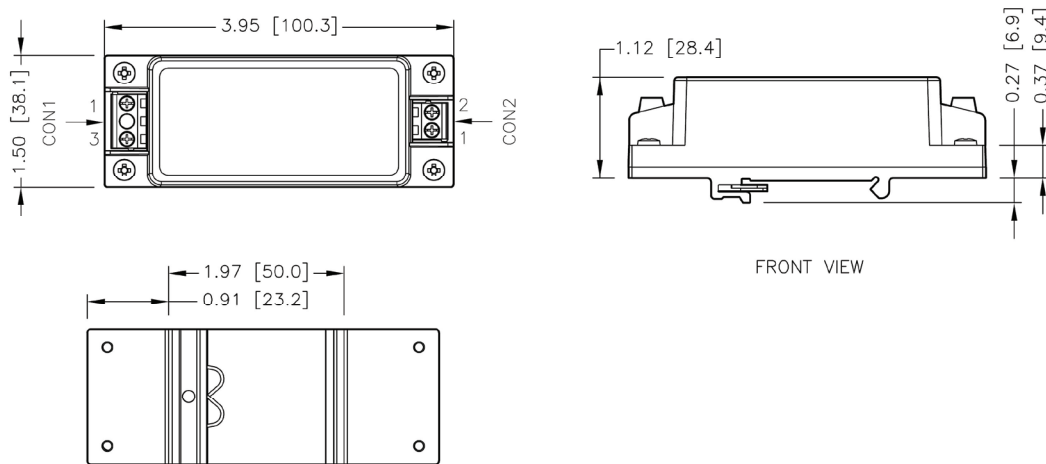

Pin Type, Suffix "D"

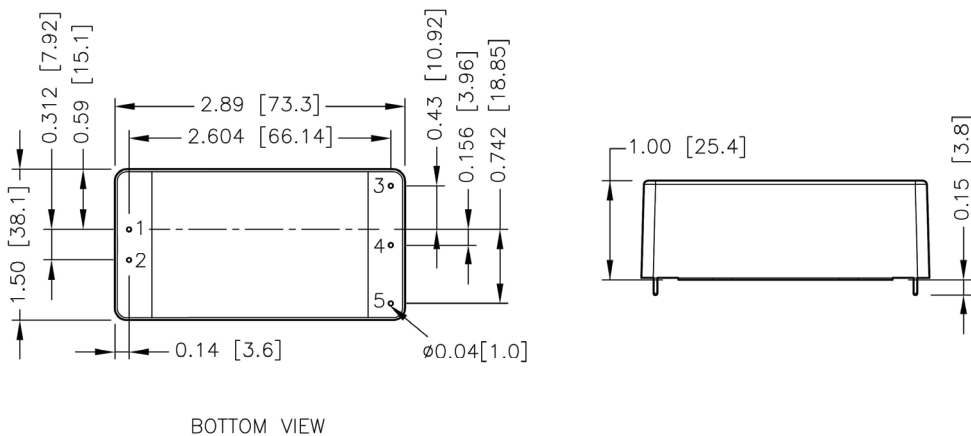

CONNECTORS

PIN	Input
1	Line
3	Neutral

	Output
1	+Vout
2	-Vout

1. All dimensions in inches (mm)
2. Tolerance :x.xx±0.02 (x.x±0.5)
x.xxx±0.01 (x.xx±0.25)
3. Pin pitch tolerance ±0.01 (0.25)
4. Pin dimension tolerance ±0.004 (0.1)

KUI30 SERIES

Output Voltage Adjustment

It allows the user to increase or decrease the output voltage of the module.

This is accomplished by connecting an external resistor between the Trim pin and either the +Vout or -Vout pins.

With an external resistor between the Trim and -Output pin, the output voltage increases.

With an external resistor between the Trim and +Output pin, the output voltage decreases.

The external Trim resistor needs to be at least 1/16W of rated power.

Trim Up Equation

$$R_U = \left[\frac{G \times L}{(V_{O,up} - L - K)} - H \right] \Omega$$

Trim Down Equation

$$R_D = \left[\frac{(V_{o,down} - L) \times G}{(V_o - V_{o,down})} - H \right] \Omega$$

Module	G	H	K	L
KUI30-33SB	5100	2050	0.8	2.5
KUI30-5SB	7500	2000	2.5	2.5
KUI30-7.5SB	22000	2000	5	2.5
KUI30-9SB	33000	2000	6.5	2.5
KUI30-12SB	51000	2000	9.5	2.5
KUI30-15SB	68000	2000	12.5	2.5
KUI30-18SB	91000	2000	15.5	2.5
KUI30-24SB	130000	2000	21.5	2.5
KUI30-28SB	160000	2000	25.5	2.5
KUI30-36SB	220000	2000	33.5	2.5
KUI30-48SB	620000	2000	45.5	2.5
KUI30-53SB	680000	2000	50.5	2.5

Recommended Pad Layout

Pin Type, Suffix "D"

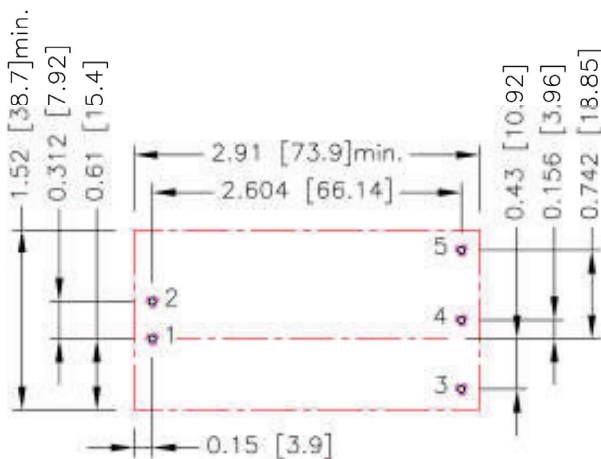

1. All dimensions in inches (mm)
2. Pad size (lead free recommended)
3. Through hole 1, 2, 3, 4, 5: $\Phi 0.051(1.3)$
4. Top view pad 1, 2, 3, 4, 5: $\Phi 0.064(1.63)$
5. Bottom view pad 1, 2, 3, 4, 5: $\Phi 0.102(2.6)$

KUI30 SERIES

Output Voltage Adjustment (continued)

EXTERNAL OUTPUT TRIMMING

Output can be externally trimmed by using the method shown below.

Trim-up

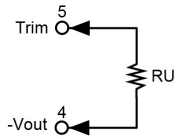

KUI30-33SB

ΔV (%)	1	2	3	4	5	6	7	8	9	10
Vout (V)	3.333	3.366	3.399	3.432	3.465	3.498	3.531	3.564	3.597	3.630
RU (k Ω)	384.314	191.132	126.738	94.541	75.223	62.344	53.145	46.245	40.879	36.586

KUI30-5SB

ΔV (%)	1	2	3	4	5	6	7	8	9	10
Vout (V)	5.050	5.100	5.150	5.200	5.250	5.300	5.350	5.400	5.450	5.500
RU (k Ω)	373.000	185.500	123.000	91.750	73.000	60.500	51.571	44.875	39.667	35.500

KUI30-7.5SB

ΔV (%)	1	2	3	4	5	6	7	8	9	10
Vout (V)	7.575	7.650	7.725	7.800	7.875	7.950	8.025	8.100	8.175	8.250
RU (k Ω)	731.333	364.667	242.444	181.333	144.667	120.222	102.762	89.667	79.481	71.333

KUI30-9SB

ΔV (%)	1	2	3	4	5	6	7	8	9	10
Vout (V)	9.090	9.180	9.270	9.360	9.450	9.540	9.630	9.720	9.810	9.900
RU (k Ω)	914.667	456.333	303.556	227.167	181.333	150.778	128.952	112.583	99.852	89.667

KUI30-12SB

ΔV (%)	1	2	3	4	5	6	7	8	9	10
Vout (V)	12.120	12.240	12.360	12.480	12.600	12.720	12.840	12.960	13.080	13.200
RU (k Ω)	1060.500	529.250	352.167	263.625	210.500	175.083	149.786	130.813	116.056	104.250

KUI30-15SB

ΔV (%)	1	2	3	4	5	6	7	8	9	10
Vout (V)	15.150	15.300	15.450	15.600	15.750	15.900	16.050	16.200	16.350	16.500
RU (k Ω)	1131.333	564.667	375.778	281.333	224.667	186.889	159.905	139.667	123.926	111.333

KUI30-18SB

ΔV (%)	1	2	3	4	5	6	7	8	9	10
Vout (V)	18.180	18.360	18.540	18.720	18.900	19.080	19.260	19.440	19.620	19.800
RU (k Ω)	1261.889	629.944	419.296	313.972	250.778	208.648	178.556	155.986	138.432	124.389

KUI30-24SB

ΔV (%)	1	2	3	4	5	6	7	8	9	10
Vout (V)	24.240	24.480	24.720	24.960	25.200	25.440	25.680	25.920	26.160	26.400
RU (k Ω)	1352.167	675.083	449.389	336.542	268.833	223.694	191.452	167.271	148.463	133.417

KUI30-28SB

ΔV (%)	1	2	3	4	5	6	7	8	9	10
Vout (V)	28.280	28.560	28.840	29.120	29.400	29.680	29.960	30.240	30.520	30.800
RU (k Ω)	1426.571	712.286	474.190	355.143	283.714	236.095	202.082	176.571	156.730	140.857

KUI30-36SB

ΔV (%)	1	2	3	4	5	6	7	8	9	10
Vout (V)	36.360	36.720	37.080	37.440	37.800	38.160	38.520	38.880	39.240	39.600
RU (k Ω)	1525.778	761.889	507.259	379.944	303.556	252.630	216.254	188.972	167.753	150.778

KUI30-48SB

ΔV (%)	1	2	3	4	5	6	7	8	9	10
Vout (V)	48.480	48.960	49.440	49.920	50.400	50.880	51.360	51.840	52.320	52.800
RU (k Ω)	3227.167	1612.583	1074.389	805.292	643.833	536.194	459.310	401.646	356.796	320.917

KUI30-53SB

ΔV (%)	1	2	3	4	5	6	7	8	9	10
Vout (V)	53.530	54.060	54.590	55.120	55.650	56.180	56.710	57.240	57.770	58.300
RU (k Ω)	3205.547	1601.774	1067.182	799.887	639.509	532.591	456.221	398.943	354.394	318.755

KUI30 SERIES

Output Voltage Adjustment (continued)

EXTERNAL OUTPUT TRIMMING

Output can be externally trimmed by using the method shown below.

Trim-down

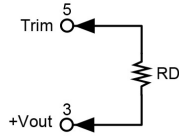

KUI30-33SB

ΔV (%)	1	2	3	4	5	6	7	8	9	10
Vout (V)	3.267	3.234	3.201	3.168	3.135	3.102	3.069	3.036	3.003	2.970
RD (k Ω)	116.486	54.668	34.062	23.759	17.577	13.456	10.512	8.305	6.587	5.214

KUI30-5SB

ΔV (%)	1	2	3	4	5	6	7	8	9	10
Vout (V)	4.950	4.900	4.850	4.800	4.750	4.700	4.650	4.600	4.550	4.950
RD (k Ω)	365.500	178.000	115.500	84.250	65.500	53.000	44.071	37.375	32.167	365.500

KUI30-7.5SB

ΔV (%)	1	2	3	4	5	6	7	8	9	10
Vout (V)	7.425	7.350	7.275	7.200	7.125	7.050	6.975	6.900	6.825	6.750
RD (k Ω)	1442.667	709.333	464.889	342.667	269.333	220.444	185.524	159.333	138.963	122.667

KUI30-9SB

ΔV (%)	1	2	3	4	5	6	7	8	9	10
Vout (V)	8.910	8.820	8.730	8.640	8.550	8.460	8.370	8.280	8.190	8.100
RD (k Ω)	2348.333	1156.667	759.444	560.833	441.667	362.222	305.476	262.917	229.815	203.333

KUI30-12SB

ΔV (%)	1	2	3	4	5	6	7	8	9	10
Vout (V)	11.880	11.760	11.640	11.520	11.400	11.280	11.160	11.040	10.920	10.800
RD (k Ω)	3984.500	1965.750	1292.833	956.375	754.500	619.917	523.786	451.688	395.611	350.750

KUI30-15SB

ΔV (%)	1	2	3	4	5	6	7	8	9	10
Vout (V)	14.850	14.700	14.550	14.400	14.250	14.100	13.950	13.800	13.650	13.500
RD (k Ω)	5596.667	2763.333	1818.889	1346.667	1063.333	874.444	739.524	638.333	559.630	496.667

KUI30-18SB

ΔV (%)	1	2	3	4	5	6	7	8	9	10
Vout (V)	17.820	17.640	17.460	17.280	17.100	16.920	16.740	16.560	16.380	16.200
RD (k Ω)	7743.111	3825.056	2519.037	1866.028	1474.222	1213.019	1026.444	886.514	777.679	690.611

KUI30-24SB

ΔV (%)	1	2	3	4	5	6	7	8	9	10
Vout (V)	23.760	23.520	23.280	23.040	22.800	22.560	22.320	22.080	21.840	21.600
RD (k Ω)	11513.833	5690.917	3749.944	2779.458	2197.167	1808.972	1531.690	1323.729	1161.981	1032.583

KUI30-28SB

ΔV (%)	1	2	3	4	5	6	7	8	9	10
Vout (V)	27.720	27.440	27.160	26.880	26.600	26.320	26.040	25.760	25.480	25.200
RD (k Ω)	14409.429	7123.714	4695.143	3480.857	2752.286	2266.571	1919.633	1659.429	1457.048	1295.143

KUI30-36SB

ΔV (%)	1	2	3	4	5	6	7	8	9	10
Vout (V)	35.640	35.280	34.920	34.560	34.200	33.840	33.480	33.120	32.760	32.400
RD (k Ω)	20250.222	10014.111	6602.074	4896.056	3872.444	3190.037	2702.603	2337.028	2052.691	1825.222

KUI30-48SB

ΔV (%)	1	2	3	4	5	6	7	8	9	10
Vout (V)	47.520	47.040	46.560	46.080	45.600	45.120	44.640	44.160	43.680	43.200
RD (k Ω)	58148.833	28763.417	18968.278	14070.708	11132.167	9173.139	7773.833	6724.354	5908.093	5255.083

KUI30-53SB

ΔV (%)	1	2	3	4	5	6	7	8	9	10
Vout (V)	52.470	51.940	51.410	50.880	50.350	49.820	49.290	48.760	48.230	47.700
RD (k Ω)	64110.453	31714.226	20915.484	15516.113	12276.491	10116.742	8574.065	7417.057	6517.161	5797.245